

# 3AEH500 Relay Protection

## Installation and Operation Manual V2.1

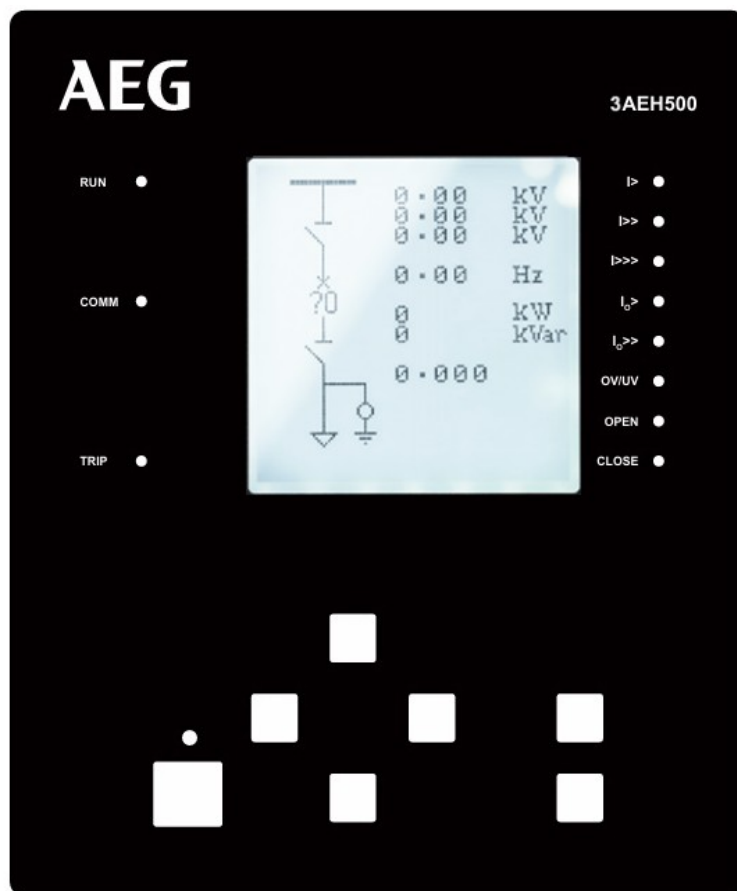

### About This Manual

This manual is intended to provide users with basic information about the 3AEH500 Programmable Digital Protection and Control Device, with a focus on the operation of the Human-Machine Interface (HMI).

### Symbols Used

The following icons included in this manual indicate safety-related conditions or other important information:



Electrical Warning Icon: Indicates the presence of potential electric shock hazards.



Warning Icon: Indicates the possibility of property damage, personal injury, or even death.



Information Icon: Reminds readers of relevant facts and conditions.

Warnings and alerts regarding potential property damage, personal injury, or death must be strictly adhered to; therefore, all warning and alert instructions must be followed explicitly.

### Safety Information

Personnel involved in the installation, commissioning, maintenance, or repair of the 3AEH500 Programmable Digital Protection and Control Device must possess appropriate qualifications and carefully read this manual.



Warning: The terminals on the back panel of the 3AEH500 Programmable Digital Protection and Control Device may have hazardous voltages, even several seconds after disconnecting the auxiliary power supply. The device must be properly grounded by connecting the grounding bolt on the back panel of the device to a good earth ground.



Warning: The 3AEH500 Programmable Digital Protection and Control Device contains electrostatically sensitive components. When opening the chassis, it is necessary to wear a properly grounded anti-static wrist strap and avoid unnecessary contact with the components.



Warning: To prevent electric shock, always disconnect the device from the power outlet before opening the chassis.



Warning: Do not install the 3AEH500 Programmable Digital Protection and Control Device in environments with water infiltration, drastic temperature changes, persistent strong vibrations, high dust levels, flammable or explosive gases, or corrosive gases.



Information: Breaking the device seal will void the warranty and no longer ensure normal operation.

## Table of Contents

2	
<b>1. Introduction</b>	<b>3</b>
<b>2. Front View of the Device</b>	<b>4</b>
<b>2.1 Display Description</b>	<b>4</b>
<b>2.2 Indicator Light Description</b>	<b>5</b>
<b>2.3 Button Description</b>	<b>6</b>
<b>3. Device Operation</b>	<b>7</b>
<b>3.1 Power On</b>	<b>7</b>
<b>3.2 Quick Navigation</b>	<b>8</b>
<b>3.3 Main Screen</b>	<b>8</b>
<b>3.4 User Login</b>	<b>8</b>
<b>3.5. Downloading Data</b>	<b>9</b>
<b>3.6. Main Menu</b>	<b>9</b>
<b>3.6.1 Measurement Information</b>	<b>10</b>
<b>3.6.2 Status Information</b>	<b>11</b>
<b>3.6.3 Event Records</b>	<b>11</b>
<b>3.6.4 Device Testing</b>	<b>12</b>
<b>3.6.5 Parameter Settings</b>	<b>12</b>
<b>3.6.6 System Information</b>	<b>13</b>
<b>4. 3AEH500 Device Dimensions and Installation Dimensions</b>	<b>15</b>
<b>5. 3AEH500 Device Rear Terminal Diagram</b>	<b>18</b>
<b>6. Electrical Wiring</b>	<b>19</b>
<b>6.1. AC Wiring</b>	<b>19</b>
<b>6.2. DI/DO Wiring</b>	<b>20</b>
<b>6.3. Communication Wiring</b>	<b>21</b>
<b>6.4. Power Supply and Grounding</b>	<b>22</b>
<b>7. Maintenance and Common Issue Troubleshooting</b>	<b>23</b>
<b>8. Product Function code</b>	<b>24</b>
<b>Appendix A: 3AEH500 Protection Device Factory Default Settings Table</b>	<b>30</b>
<b>Appendix B: MODBUS-RTU Setting Function Codes and Address Table</b>	<b>32</b>
1. Function Codes "01H", "05H": Read/Write or Multiple Switch Outputs	32
2. Function Code "02H": Read Single or Multiple Digital Input States	35
3. Function Codes "03H", "06H", "10H": Read/Write Registers	36
3.1 Time	36
3.2 Electrical degree	36
3.3 Substation (R: 03H, W:06H)	37

---

3.3.1 Substation status register (0150) .....	37
3.4 analog quantity .....	37
3.5 Settings.....	39

### **Appendix C: IEC60870-5-103 Protocol Setting Value Function Codes and Address**

<b>Table</b> .....	43
Table 1: Telemetry (ASDU50) .....	43
Table 2: Telesignalling (ASDU1).....	44
Table 3: Electricity Metering (ASDU36) .....	47
Table 4: Remote Control (ASDU64) .....	47

## 1. Introduction

The 3AEH500 series of programmable digital protection and control devices are a new generation of digital relay protection and control terminals developed by our company. Adopting a large-capacity, resource-redundant design, they are suitable for protection, control, measurement, and monitoring of power grids with voltage levels of 35kV and below. They are available as programmable microcomputer relay protection devices for various functions such as line protection, incoming line backup switching, capacitor protection, motor protection, and PT voltage transformer protection. They can be used in different main wiring configurations, such as single busbar, double busbar, and multi-busbar wiring. They are also suitable for different system operation modes, including neutral point ungrounded systems, low-resistance grounded systems, and arc suppression coil grounded systems.

In addition to protection, measurement, control, and status monitoring functions, the 3AEH500 also provides PLC logic programmable functionality supporting the IEC-61131-3 graphical programmable standard. The PLC function integrates the automation functions and sequential logic control functions required for substation automation systems into a single device. It can store 4 sets of protection settings, and the convenient group switching function allows it to quickly adapt to multiple operation modes. Using the GLPSet software, the 3AEH500 can be configured as a protection device for different applications.

The 3AEH500 series devices collect full electrical quantities, with measurement current and protection current circuits being independent of each other, which improves protection reliability and ensures measurement accuracy. The high-precision measurement function ensures that voltage, current, and power factor reach 0.2-class accuracy, and four-quadrant power measurement and energy metering reach 0.5-class accuracy.

The 3AEH500 can store 8 sets of time-stamped waveform records, covering 4 cycles before the trigger moment and 24 cycles after, totaling 28 cycles of data, with 32 points sampled per cycle. At each sampling point, all AC inputs, switch inputs, switch outputs, and protection modules are collected and recorded in real-time.

The 3AEH500 series supports IRIG-B code synchronization, provides two RS485 standard channels and an Ethernet port, supports Modbus and IEC60870-5-103 communication protocols, and can use different protocols on different networks, providing users with highly reliable network communication.

An optional GPRS wireless communication module and anti-bouncing device can also be selected.

## 2.Front View of the Device

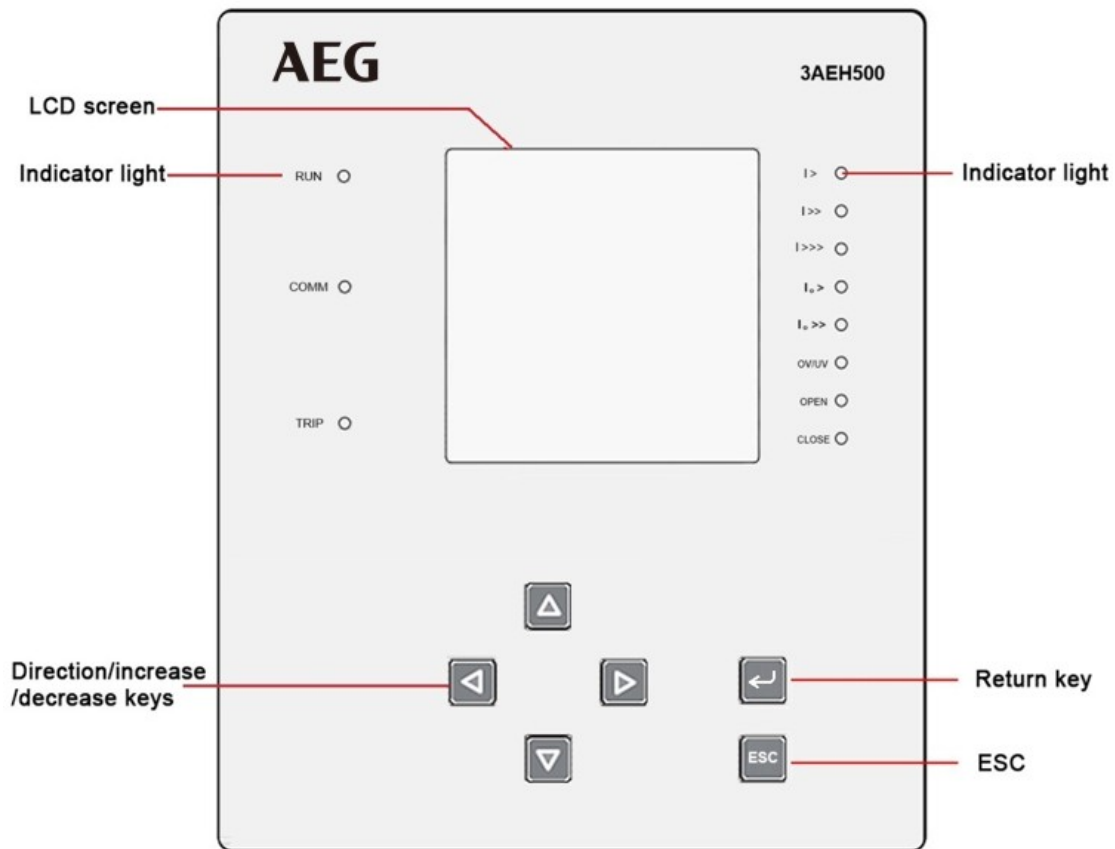

Figure 1: 3AEH500 Device Panel

### 2.1 Display Description

The 3AEH500 features a 128\*128 dot matrix large LCD display that can display letters

and Chinese characters with backlighting.

Settings for the 3AEH500 are performed on the panel, where users can adjust settings such as device parameters and settings through button operations. Device status can be observed through the LCD display and LED lights. Alternatively, the device can be connected to a computer via the included data cable, allowing for more convenient querying and setting of parameters through the accompanying GLPSet software on the computer. Various information can be displayed, such as:

- Real-time values of measurement current, voltage, power, etc.
- Event reports (SOE)
- Various device parameters
- Various setting parameters
- Device version, serial number, self-test information, etc.
- Time, etc.

### 2.2 Indicator Light Description

There are a total of 11 indicator lights on the panel.

The meanings of the left indicator lights from top to bottom are:

Power Indicator: Green, blinks when the unit is operating normally.

Communication Indicator: Red, lights up when normal communication is occurring.

Fault Indicator: Red, lights up when there is a fault.

The meanings of the right indicator lights from top to bottom are:

Protection 1: Dual-color light - red and yellow.

Protection 2: Dual-color light - red and yellow.

Protection 3: Dual-color light - red and yellow.

Protection 4: Dual-color light - red and yellow.

Protection 5: Dual-color light - red and yellow.

Protection 6: Dual-color light - red and yellow.

Protection 7: Dual-color light - red and yellow.



Protection 8: Dual-color light - red and yellow.

## 2.3 Button Description

There are 6 buttons on the panel, and their functions are shown in the following table (Table 1).



















Button	Icon	Brief Description
"Up"/"Down" Button	 	Moves the cursor up/down or increases/decreases values.
"Left"/"Right" Button	 	Moves the cursor left/right or switches between main screens.
"Confirm" Button		Enters the next menu level or performs actions as prompted on the screen.
"Return"/"Cancel" Button		Returns to the previous menu level or performs actions as prompted on the screen.

Table 1 Button Description Table

### Multi-functional operation

Login/Login out	 + 
Reset	 + 
CLOSE BREAKER	 +  +  + 
OPEN BREAKER	 +  +  + 

### Combination Buttons:

(1) SOE (Event Record) Clear Button: On the event record screen, simultaneously press the "Confirm" and "Return" buttons to clear existing event records.

(2) "Login/Logout" Button: On any screen, simultaneously press the "Up" and "Confirm" buttons. When not logged in, pressing this combination button directly enters the login screen. After successful login, pressing this combination button directly enters the logout screen to

choose whether to logout. (After unlocking with a password, if there is no operation for 60 seconds, the password protection will take effect again.)

(3) "Reset" Button: On any screen, simultaneously press the "Up" and "Return" buttons to reset signal indicator lights, hold-type relays, and signal relays.

(4) "Remote/Local" Switch Button: Simultaneously press the "Left" and "Right" buttons to switch between remote and local control.

(5) "Manual Close": Simultaneously press the "Right" and "Confirm" buttons to manually select an object to close.

(6) "Manual Open": Simultaneously press the "Left" and "Confirm" buttons to manually select an object to open.

### 3. Device Operation

#### 3.1 Power On

After powering on the device, the display shows a predefined startup screen. At this time, observe the LCD display for any abnormalities such as missing segments to determine its condition. The 11 indicator lights light up, and users can observe whether these lights are correct.

The screen progresses to the "Event Record" screen, generating an "Device Powered On" SOE. While starting up, the device also performs self-tests on items such as the clock, settings, logic data, power supply voltage, flash memory, and internal temperature. If all self-test items pass, the device's abnormal alarm relay activates, emitting a "click" sound, and the normally closed contact opens. After

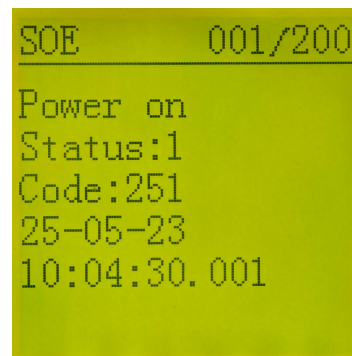

```
SOE      001/200
Power on
Status:1
Code:251
25-05-23
10:04:30.001
```

successful startup, the screen progresses to the event record screen, generating an "Device Powered On" event record, and immediately enabling the protection logic module; if any self-test items fail, the device's abnormal alarm relay does not activate, the normally closed contact outputs an alarm signal, and the screen generates a "Self-Test Error" event record, disabling the protection logic module.

After a period of time, the screen will automatically switch to the main screen shown on the right, or pressing the "Return" button three times after appearing on the SOE screen will switch the screen to the main screen shown on the right.

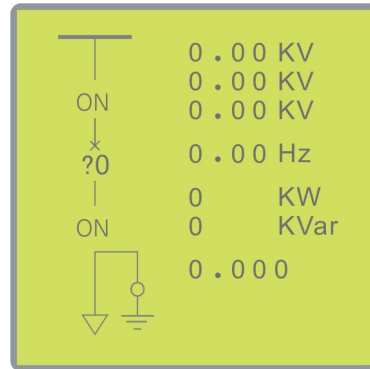

### 3.2 Quick Navigation

The 3AEH500 menu listed below is the main menu for visualizing settings such as settings, measurements, and changes through the HMI. On the main menu screen, press the "Left" or "Right" button to switch between the monitoring screen and the operation screen. Press the "Confirm" button to enter the next submenu level or execute related actions, and press the "Return" button to return to the previous menu. Users can select the correct path according to actual needs.

### 3.3 Main Screen

The main screen has two pages: the "Operation Screen" and the "Monitoring Screen," as shown below. You can flip through them to view them in sequence by pressing the "Left" and "Right" buttons.

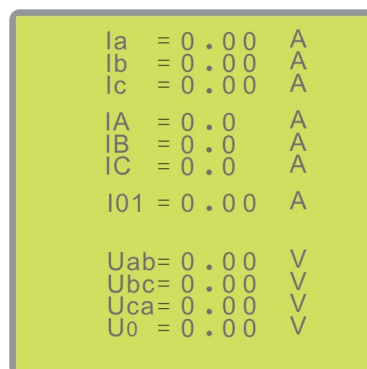
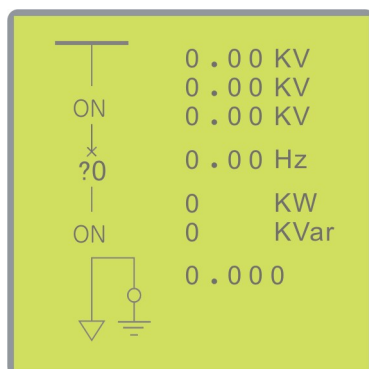

### 3.4 User Login

The 3AEH500 uses a password protection program. When

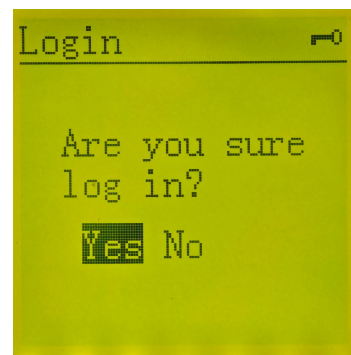

not logged in, users can only observe various screens but cannot modify any parameters of the device. To modify device parameters, users must first log in by entering the correct password. Only after successful login can users make corresponding parameter modifications to the device. The user login steps are as follows:

Press the "Up + Confirm" combination button to enter the login screen. Use the "Up" and "Down" buttons to modify digits, the "Left" and "Right" buttons to move the cursor, and input the correct password. Then press the "Confirm" button, and the screen switches to the one shown on the right. Select "Yes" and press the "Confirm" button to confirm login. Select "No" and press the "Confirm" button to cancel login, and the screen returns to the main menu.

Users can determine whether login was successful by observing the lock icon in the upper right corner of the screen. The presence of a lock icon indicates that the device is locked and the user login failed; the absence of a lock icon indicates that it is unlocked and the user login was successful. When the password is entered incorrectly, the screen displays the message "Password Error!" Press the "ESC" button to switch the screen to the "Main Menu" screen, or do not perform any operation, and wait for 60 seconds for the screen to automatically switch to the operation screen.



**Information: The factory default password is: 0000**

### 3.5. Downloading Data

Device parameters, settings, and other data can be set through two paths: one is to set the device's parameters, settings, and other data through the accompanying GLPSet software, and the other is to set them through button operations on the panel. Regardless of the menu screen the device is on, data such as parameters and settings can be downloaded to the device after connecting the included data cable between the computer and the device.

### 3.6. Main Menu

Pressing the "Confirm" button on any main screen enters the main menu, which has a total of 6 items, including "Measurement Information," "Status Information," "Event Records," "Device Testing," "Parameter Settings," and "System

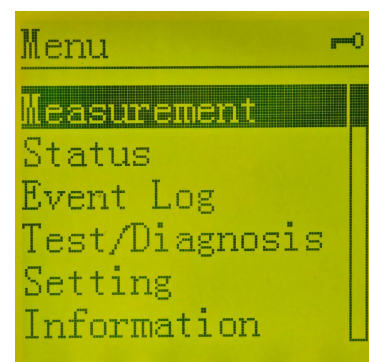

Information." You can cycle through the main menu options using the "Up" and "Down" buttons. The selected item is highlighted in reverse video. Press the "Confirm" button to enter the next submenu level of the selected menu, and press the "Return" button to return to the main screen.

Number	Submenu Name	Brief Description
1	Measurement Information	View measurement parameters
2	Status Information	View status parameters
3	Event Records	View event records
4	Device Testing	View device test information
5	Parameter Settings	Set device parameters
6	System Information	Browse device information

### 3.6.1 Measurement Information

Select the "Measurement Information" submenu in the main menu and press the "Confirm" button to enter submenu level. Measurement information includes sampling values, angle values, primary values, secondary values, energy values, and other measurement information. From this measurement information, you can intuitively and clearly understand the current data collected by the device. All values in the measurement information can only be viewed and are real-time data collected by the device. Press the "Return" button to return to the previous menu.

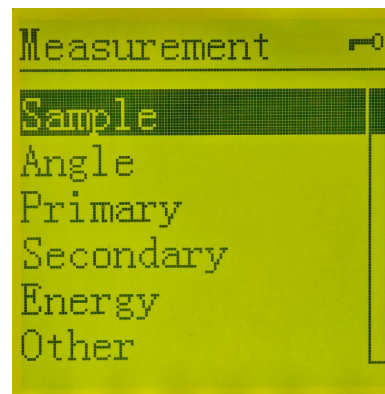

in this the

Measurement Information	
Submenu	Measurement Data
Sampling Value	Current and voltage values of the protection channel, zero-sequence channel, and measurement channel.
Angle Value	Current and voltage angle values of the protection, zero-sequence, and measurement channels.
Primary Value	Measured primary values.
Secondary	Measured secondary values.

Value	
Energy Value	Measured active, reactive, and other energy values.
Other	Other parameters.

### 3.6.2 Status Information

Select the "Status Information" submenu in the main menu and press the "Confirm" button to enter this submenu. This menu contains the "System Time," "DI Status," "DO Status," and "Self-Test Status" submenu options. The cursor position will be highlighted in reverse video. Press the "Confirm" button again, and the screen will jump to the next submenu level of the selected item. All content in this menu can only be viewed and cannot be



modified. Through this window, you can directly observe the current status of the device, intuitively reflecting its current working condition.

DI/DO		
Menu Item	Content	Status
System Time	Time	
DI Status	Real-time status of DI01 to DI10	0 or 1 (0 indicates no signal input, 1 indicates signal input).
DO Status	Real-time status of DO01 to DO7	0 or 1 (0 indicates no signal output, 1 indicates signal output).
Self-Test Status	Device item self-test information.	

### 3.6.3 Event Records

The "Event Records" menu is used to record all event information that has occurred on the device, with a total capacity of 100 records. It records based on the first-in, first-out principle, meaning the 101st record overwrites the first record, cycling through. The content displayed on the event record screen includes: event record sequence

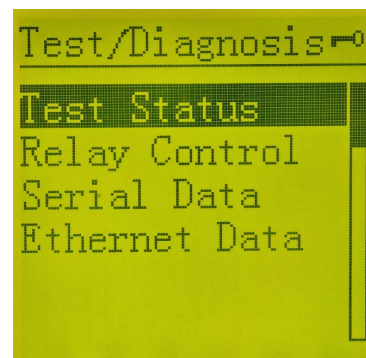

number, total number of event records, event name, status after transition, SOE code, event occurrence time (accurate to milliseconds). If the event record is caused by a protection action, it will also record the action value of the action element at the event occurrence time.

Event Name	SOE Code	Remarks
Remote Reset	246	Refers to a protection reset command sent through the communication port.
Local Reset	247	Refers to a protection reset performed through device buttons.
Self-Test Error	248	Device self-test failed.
Self-Test Correct	249	Device self-test passed.
Device Powered Off	250	Device powered off or voltage insufficiency exceeds 100ms.
Device Powered On	251	Device restarted after a power failure.
Device Reset	252	Device restarted without a power failure.
Local Operation	253	Refers to an export operation performed through device buttons.
Remote Operation	254	Refers to an export operation performed through communication commands.
Setting Modification	255	Includes modifications to settings and enable/disable control words (through device buttons or communication).

### 3.6.4 Device Testing

Select the "Device Testing" submenu in the main menu and press the "Confirm" button to enter this submenu. This menu contains the "Test Status," "DO Control," "Serial Port Data," and "Ethernet Data" submenu options.

### 3.6.5 Parameter Settings

Select "Parameter Settings" in the main menu and press the "Confirm" button to enter the parameter settings menu. This menu has a total of 13 submenus, namely "Operation Configuration," "Channel Coefficients," "Group A Settings," "Group B Settings," "Group C Settings," "Group D Settings," "Switch Settings," "Communication

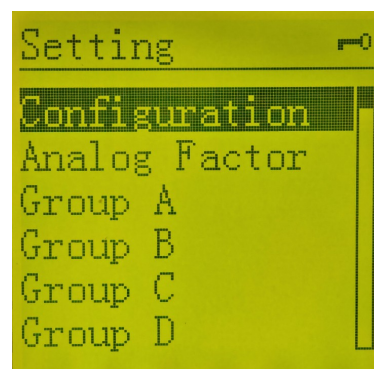

Settings," "DI Settings," "Energy Settings," "Password Settings," "Time Settings," and "Language Settings," encompassing the basic parameters for device settings. Users can move the cursor using the "Up" and "Down" buttons and press the "Confirm" button to enter the selected submenu to modify parameters. Parameter viewing does not require a password, but modifications are password-protected. Users must log in successfully to make modifications.

### 3.6.6 System Information

By selecting the "System Information" option under the main menu, this menu displays information such as name, version number, and serial number. The serial number serves the purpose of device authentication.

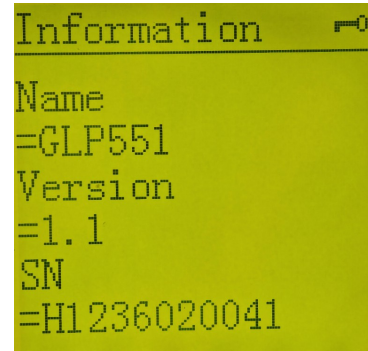

```
Information  F0
-----
Name
=GLP551
Version
=1.1
SN
=H1236020041
```



## 4. 3AEH500 Device Dimensions and Installation

### Dimensions

External Dimensions and Cutout Dimensions:

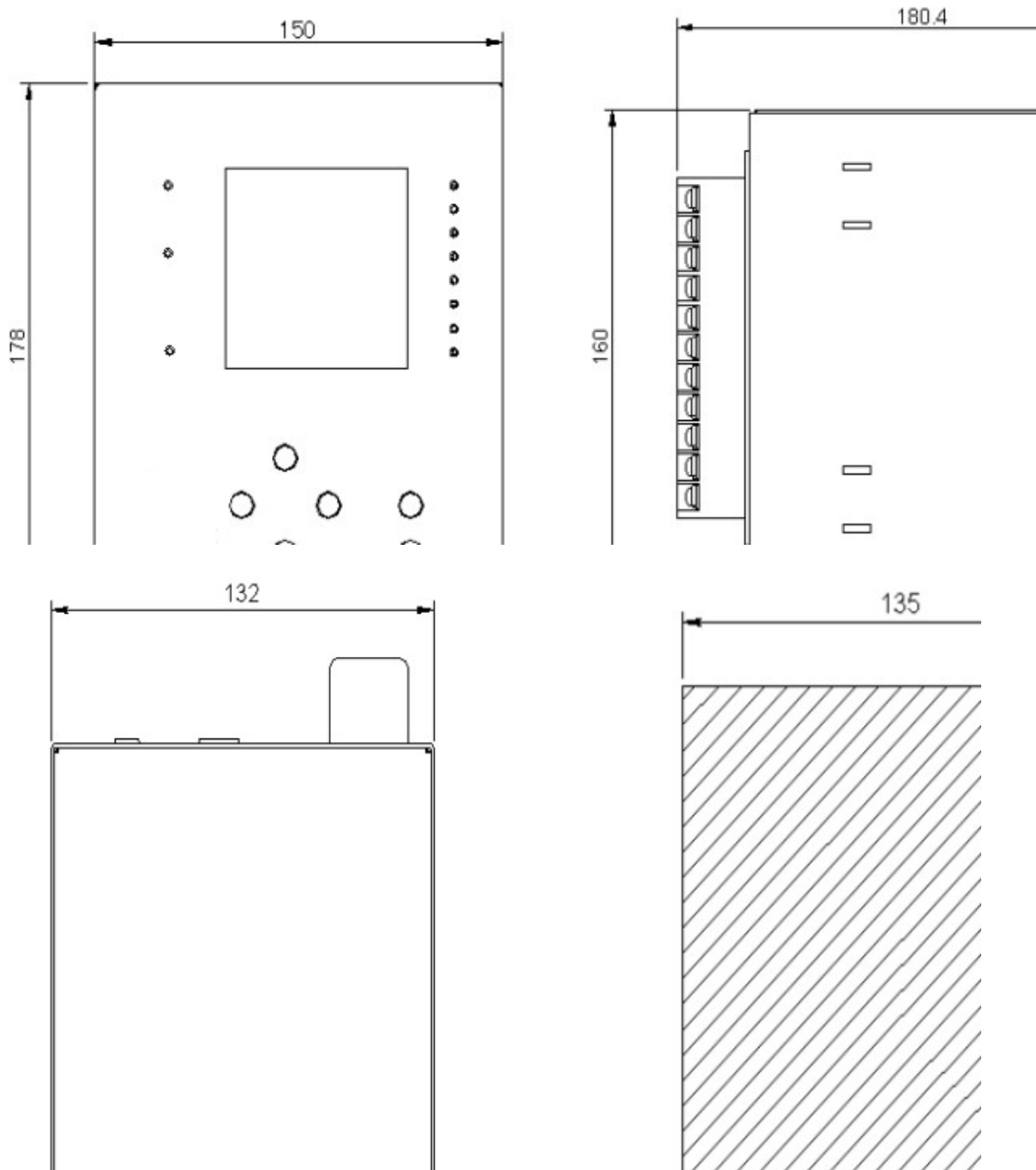

## Installation Steps:

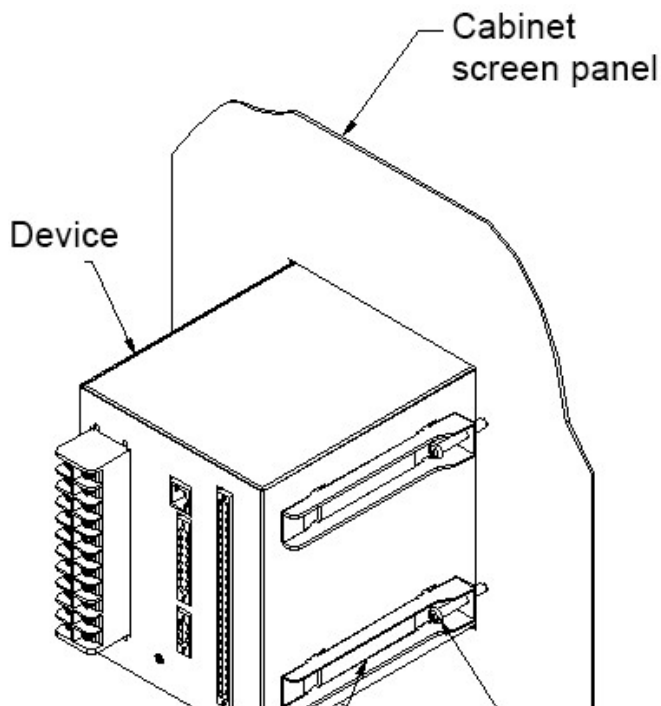
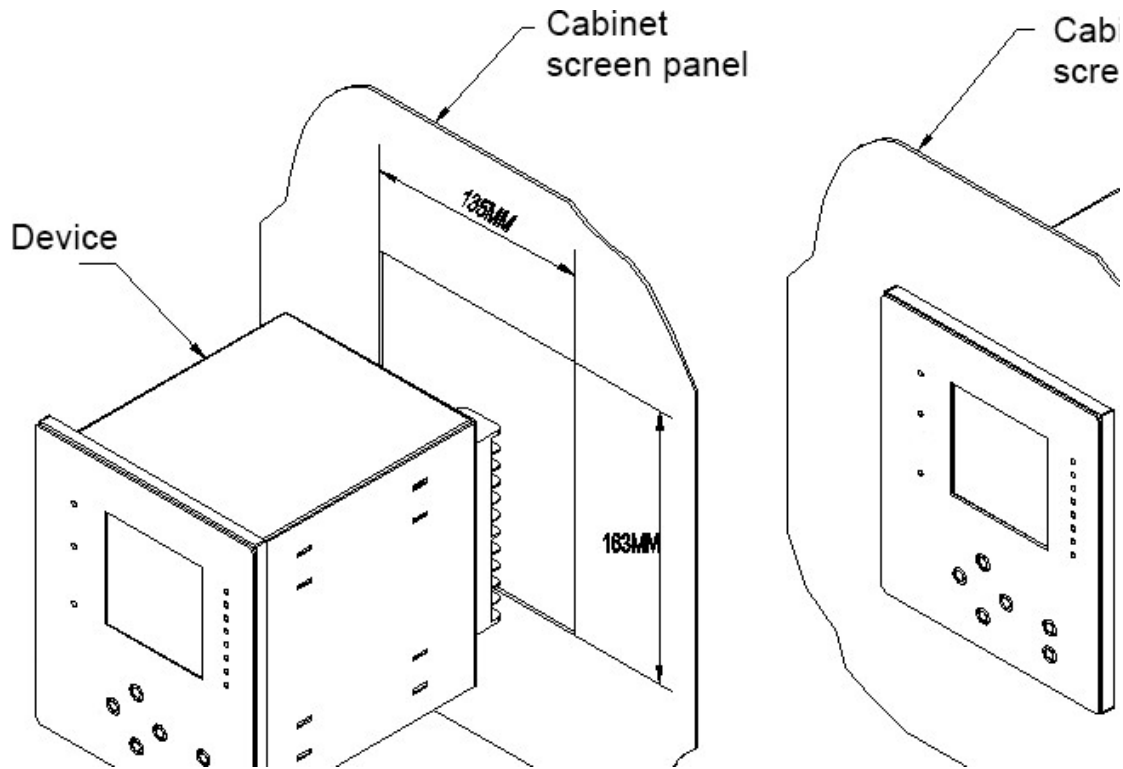

As shown in Figure 1:  
First, make square holes c  
screen panel  
(Size: 135 × 163)

As shown in Figure 2:  
Place the chassis equipme  
square hole until the equip  
against the cabinet panel

As shown in Figure 3:  
Insert the four randomly as  
installation blocks, with ea  
four legs inserted into the  
rectangular holes on the c  
back slightly with force to  
chassis, as shown in Figur  
hold down the installation  
with your hand and rotate

### 3AEH500 External Dimensions and Installation Dimensions (Unit: mm)

The 3AEH500 is suitable for local installation on switchgear or screen installation. Cut out

the shaded area on the cabinet panel according to the above cutout dimensions, import the 3AEH500 from the front, insert the 4 mounting blocks provided with the device, insert the 4 feet of each mounting block into the corresponding rectangular holes on the chassis, pull slightly backward to make them latch onto the chassis, then slightly press down on the mounting block with your hand and rotate the long screws on the mounting block (note the force applied, just enough to tighten), so that the front ends of the long screws press against the panel of the cabinet screen. The installed 3AEH500 should have some surrounding space to facilitate heat dissipation, loading and unloading, wiring, and operation.



**Warning: The 3AEH500 Programmable Digital Protection and Control Device contains electrostatically sensitive components. When opening the chassis, it is necessary to wear a properly grounded anti-static wrist strap and avoid unnecessary contact with the components.**



**Do not install the 3AEH500 Programmable Digital Protection and Control Device in environments with water infiltration, drastic temperature changes, persistent strong vibrations, high dust levels, flammable or explosive gases, or corrosive gases.**

## 5. 3AEH500 Device Rear Terminal Diagram

3AEH500 Series Programmable Microcomputer Relay Protection Device Rear Terminal

Diagram

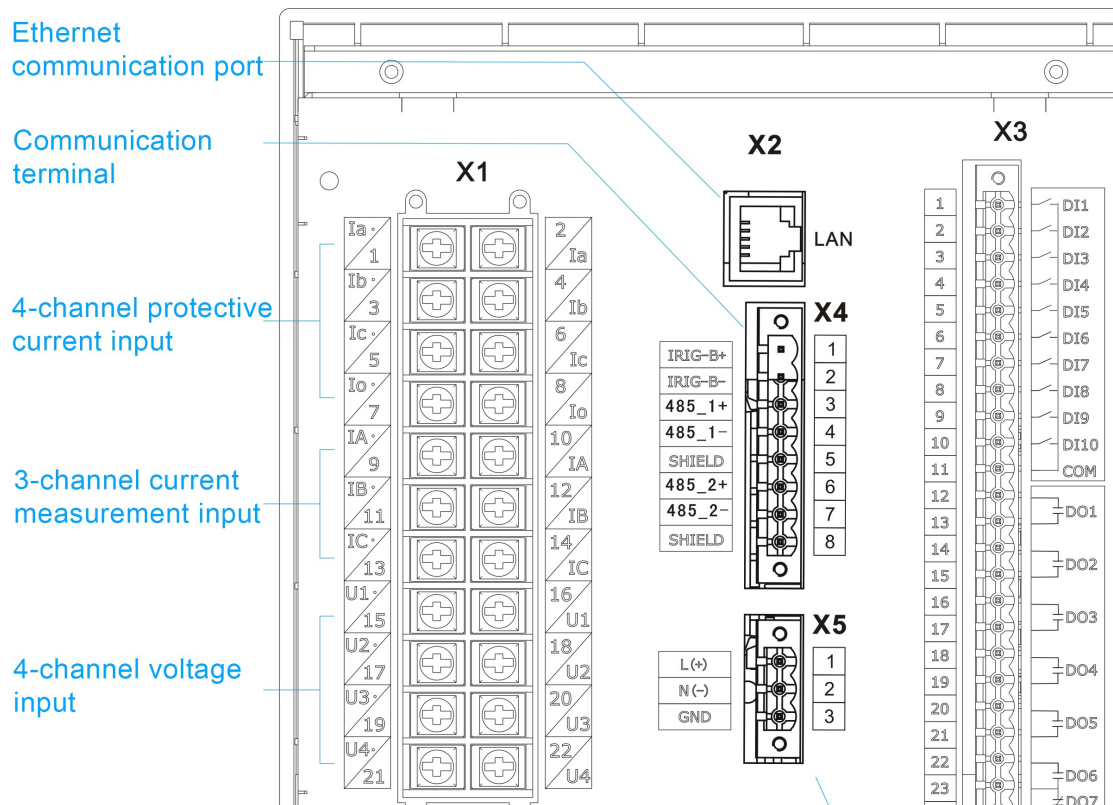

X1: AC current and voltage input terminals. X2: Ethernet communication port. X3: Switch input and output terminals. X4: Communication and timing terminals. X5: Power input terminals.



**Information:** The rear terminals of the 3AEH500 series can be selected according to user needs. Please refer to the actual situation of the selected device for specific rear terminal configurations.

## 6. Electrical Wiring



**Warning:** To prevent electric shock, always disconnect the device from the power outlet before proceeding.



The various printed circuit boards inside the 3AEH500 chassis contain many electrostatically sensitive components. When opening the chassis, it is necessary to wear a properly grounded anti-static wrist strap.

### 6.1. AC Wiring

The double-row terminal X1 on the back panel of the 3AEH500 is the AC wiring terminal, allowing the use of soft cable wiring with a maximum wire diameter of 4mm<sup>2</sup>. The 3AEH500 features a dual-CT design for measurement and protection, providing accurate measurement functionality while ensuring protection reliability. Terminals X1.1 and X1.2, X1.3 and X1.4, X1.5 and X1.6 on the back panel correspond to the A, B, and C phases of the protection CT, respectively; terminals X1.7 and X1.8 are for the zero-sequence CT, providing reliable grounding protection; terminals X1.9 and X1.10, X1.11 and X1.12, X1.13 and X1.14 correspond to the A, B, and C phases of the measurement or protection CT, respectively.

Terminals X1.15 and X1.16, X1.17 and X1.18, X1.19 and X1.20 are for the voltage A, B, and C phases, respectively, which can adopt star wiring or delta wiring according to the PT wiring method, as shown in the figure below. Terminals X1.21 and X1.22 correspond to the input of the opening voltage, cooperating with the above AC wiring to achieve full electrical input.

Terminal Number	ACConfig	1 (Mode 1)	2 (Mode 2)
1&2	Channel1	Ia	Ia
3&4	Channel2	Ib	Ib

5&6	Channel3	Ic	Ic
7&8	Channel4	I0	I0
9&10	Channel5	IA	IA
11&12	Channel6	IB	IB
13&14	Channel7	IC	IC
15&16	Channel8	Ua	Uab
17&18	Channel9	Ub	Ubc
19&20	Channel1 0	Uc	
21&22	Channel11	U0	Ubp

Table 9: AC Measurement Wiring Methods



**Information:** The protective ground connected to the AC input terminals X1 on the back panel of the 3AEH500 should be grounded near the installation location of the 3AEH500 device, not at the installation location of the CT or PT. Additionally, the installation location of the 3AEH500 device must have a good grounding system.



**AC quantities have polarity, which is a relative concept indicated by the dotted end. Polarity affects the correctness of protection, measurement, power elements, sequence components, synchronization operations, etc. Therefore, field wiring must ensure correct polarity.**

## 6.2. DI/DO Wiring

- **Standard DI**

The terminal X3 on the back panel of the 3AEH500 is the standard DI/DO wiring terminal, allowing the use of cable wiring with a maximum wire diameter of 1.5mm<sup>2</sup>. The 3AEH500 provides 10 DI channels, all of which are polarity-free and can accept AC or DC voltage. All DIs must have the same polarity because they share a common terminal.

- **Standard DO**

The DO wiring terminals are also on X3, allowing the use of cable wiring with a maximum

wire diameter of 1.5mm<sup>2</sup>. There are 7 electromagnetic relay polarity-free contacts. Except for OUT7, which is a normally closed contact output, the other 6 outputs are normally open contacts when the 3AEH500 leaves the factory. These 7 DOs are independent of each other, with each occupying two wiring terminals. The 3AEH500's DO has two output modes: pulse and self-hold.

### 6.3. Communication Wiring

- **RS485**

The 3AEH500 provides 1 RS485 communication interface. Terminals X4.3, X4.4, and X4.5 on the back panel constitute the RS485(1) communication terminals, called RS485+(1), RS485-(1), and SHIELD(1) (communication ground 1), respectively; terminals X4.6, X4.7, and X4.8 constitute the RS485(2) communication terminals, called RS485+(2), RS485-(2), and SHIELD(2) (communication ground 2), respectively. To prevent a ground current loop, the connected shielding layers and SHIELD must be grounded at only one end, typically the master station end. Ensure good connection of the shielding layers at each communication node.

- **Ethernet**

The LAN on the back panel of the 3AEH500 is Ethernet, adopting the 10base-T physical layer standard with an RJ45 connector.

The pin definitions of the 3AEH500's RJ45 adopting the 10base-T standard are shown below.

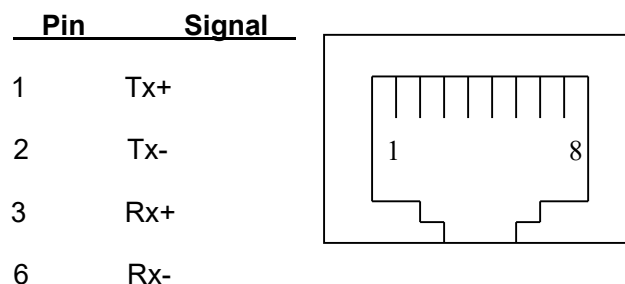

Figure 4: 3AEH500 Ethernet RJ45 Pin Definitions

The Ethernet port of the 3AEH500 uses the Modbus TCP/IP protocol.

- **IRIG-B**

IRIG-B is for time synchronization. Terminals X4.1 and X4.2 on the back panel of the 3AEH500 are for IRIG-B- and IRIG-B+ wiring, respectively.

### 6.4. Power Supply and Grounding

Terminals X5.1 and X5.2 on the back panel of the 3AEH500 are used to connect the auxiliary power supply, which is non-polar and can accept AC or DC, supplying power to the internal switching power supply. It is equipped with a built-in 3AT/250V fuse tube and power filter. Terminal X5.3 is for the high-frequency discharge ground of the auxiliary power supply, which can be separately wired to the grounding bus or led to the chassis grounding bolt but must be reliably grounded.



**Warning: Ensure that this bolt is properly grounded with a stainless steel connector, and the grounding wire cross-section should not be less than 4mm<sup>2</sup>, connected nearby to the grounding bus.**

## 7.Maintenance and Common Issue Troubleshooting

The following table lists common issues and provides troubleshooting suggestions. If the problem persists, please contact the supplier.

Category	Issue	Possible Cause	Troubleshooting Suggestion
Protection	Relay does not trip	The function is disabled or conditions are not met for tripping.	Check if the self-test information is all correct, enable the corresponding protection control word, and check if tripping conditions are met.
General	The panel indicator lights do not light up after powering the 3AEH500.	Insufficient power supply voltage, fuse blown, fuse not installed, wiring error.	Verify the power supply voltage, replace with a new 3A fuse, install a 3A fuse, and verify the auxiliary power terminal numbers.
General	After powering the 3AEH500, the displayed clock is significantly different from the actual time.	The internal button cell in the device has failed.	Replace with a new 3V button cell.
Communication	Cannot communicate with the RS485 port on the back panel of the 3AEH500.	Incorrect communication parameter settings on the PC, incorrect wiring polarity, 3AEH500 or master station not grounded, inconsistent communication parameters or protocols.	Check the communication parameter settings on the PC, swap the + and - wires, ensure both are reliably grounded, and verify the communication parameters and protocol settings.

Table 10: Common Issues and Troubleshooting Methods



**The various printed circuit boards inside the 3AEH500 chassis contain many electrostatically sensitive components. When opening the chassis, it is necessary to wear a properly grounded anti-static wrist strap.**

## 8. Product Function code

3AEH500T

Function code	Description
3I>>>(50)	Phase Instantaneous Overcurrent Protection
3I>>(67)	Low Voltage Blocked Directional Overcurrent Protection
3I>(51)	Phase Definite Time Overcurrent Protection
3I>IDMT(51)	Phase Inverse Time Overcurrent Protection
I0>(51N)	Earth fault Overcurrent Protection
I0>>(67N)	Directional Earth fault Overcurrent Protection
I0>IDMT(51N)	Earth fault Inverse Time Protection
Iub>(46)	Negative Sequence Overcurrent Protection
3I>>>>	Re-Close On Fault Protection
U0>(59N)	Zero Sequence Overvoltage Protection
Und-V Det.	Low Voltage Detection
Nnd-V Det.	No Voltage Detection
Nnd-I Det.	No Current Detection
3U<<(27)	Three-Phase Undervoltage Protection
3U>(59)	Three-Phase Overvoltage Stage II Protection
3U>>(59)	Three-Phase Overvoltage Stage I Protection
TCS1	Control Circuit Supervision
FUSEF(60)	Fuse Fail Protection
CB-Fail(51BF)	Circuit Breaker Failure Protection
Temp. Alarm	High Temperature Alarm
Temp. Trip	Over Temperature Trip
TR. Fault	Transformer Fault

## 3AEH500F

Function code	Description
3I>>>(50)	Phase Instantaneous Overcurrent Protection
3I>>(67)	Low Voltage Blocked Directional Overcurrent Protection
3I>(51)	Phase Definite Time Overcurrent Protection
3I>IDMT(51)	Phase Inverse Time Overcurrent Protection
I0>(51N)	Earth fault Overcurrent Protection
I0>>(67N)	Directional Earth fault Overcurrent Protection
I0>IDMT(51N)	Earth fault Inverse Time Protection
Iub>(46)	Negative Sequence Overcurrent Protection
O->I(79)	Reclose
3I>>>>	Re-Close On Fault Protection
U0>(59N)	Zero Sequence Overvoltage Protection
Und-V Det.	Low Voltage Detection
Nnd-V Det.	No Voltage Detection
Nnd-I Det.	No Current Detection
3U<<(27)	Three-Phase Undervoltage Protection
3U>(59)	Three-Phase Overvoltage Stage II Protection
3U>>(59)	Three-Phase Overvoltage Stage I Protection
TCS1	Control Circuit Supervision
FUSEF(60)	Fuse Fail Protection
CB-Fail(51BF)	Circuit Breaker Failure Protection

## 3AEH500M

Function code	Description
3I>>>(50)	Phase Instantaneous Overcurrent Protection
3I>>(67)	Low Voltage Blocked Directional Overcurrent Protection
3I>(51)	Phase Definite Time Overcurrent Protection
3I>IDMT(51)	Phase Inverse Time Overcurrent Protection
I0>(51N)	Earth fault Overcurrent Protection
I0>>(67N)	Directional Earth fault Overcurrent Protection
I0>IDMT(51N)	Earth fault Inverse Time Protection
Iub>(46)	Negative Sequence Overcurrent Protection
3Ith>>	Reclose
Is2tn<(48 66)	Starting Over Time Protection
51Ir	Motor Stall Protection
3I>>>>	Re-Close On Fault Protection
U0>(59N)	Zero Sequence Overvoltage Protection
Und-V Det.	Low Voltage Detection
Nnd-V Det.	No Voltage Detection
Nnd-I Det.	No Current Detection
3U<<(27)	Three-Phase Undervoltage Protection
3U>(59)	Three-Phase Overvoltage Stage II Protection
3U>>(59)	Three-Phase Overvoltage Stage I Protection
LOG Trip1	External Trip
TCS1	Control Circuit Supervision
FUSEF(60)	Fuse Fail Protection
CB-Fail(51BF)	Circuit Breaker Failure Protection

### 3AEH500C

Function code	Description
3I>>>(50)	Phase Instantaneous Overcurrent Protection
3I>>(67)	Low Voltage Blocked Directional Overcurrent Protection
3I>(51)	Phase Definite Time Overcurrent Protection
3I>IDMT(51)	Phase Inverse Time Overcurrent Protection
I0>(51N)	Earth fault Overcurrent Protection
I0>>(67N)	Directional Earth fault Overcurrent Protection
I0>IDMT(51N)	Earth fault Inverse Time Protection
Iub>(46)	Negative Sequence Overcurrent Protection
U0>(59N)	Zero Sequence Overvoltage Protection
Uub>	Low Voltage Detection
Und-V Det.	No Voltage Detection
Nnd-V Det.	No Current Detection
Nnd-I Det.	Three-Phase Undervoltage Protection
3U<<(27)	Three-Phase Overvoltage Stage II Protection
3U>(59)	Three-Phase Overvoltage Stage I Protection
3U>>(59)	External Trip
TCS1	Control Circuit Supervision
FUSEF(60)	Fuse Fail Protection
CB-Fail(51BF)	Circuit Breaker Failure Protection

## 3AEH500I

Function code	Description
3I>>>(50)	Phase Instantaneous Overcurrent Protection
3I>>(67)	Low Voltage Blocked Directional Overcurrent Protection
3I>(51)	Phase Definite Time Overcurrent Protection
3I>IDMT(51)	Phase Inverse Time Overcurrent Protection
I0>(51N)	Earth fault Overcurrent Protection
I0>>(67N)	Directional Earth fault Overcurrent Protection
I0>IDMT(51N)	Earth fault Inverse Time Protection
Iub>(46)	Negative Sequence Overcurrent Protection
BZT Trip 2	Open Incoming 2(Other)
BZT	Close Incoming 1(Self)
3I>>>>	Re-Close On Fault Protection
U0>(59N)	Zero Sequence Overvoltage Protection
Und-V Det.	Low Voltage Detection
Nnd-V Det.	No Voltage Detection
Nnd-I Det.	No Current Detection
3U<<(27)	Three-Phase Undervoltage Protection
3U>(59)	Three-Phase Overvoltage Stage II Protection
3U>>(59)	Three-Phase Overvoltage Stage I Protection
TCS1	Control Circuit Supervision
FUSEF(60)	Fuse Fail Protection
CB-Fail(51BF)	Circuit Breaker Failure Protection

**3AEH500U**

Function code	Description
U0>(59N)	Zero Sequence Overvoltage Protection
Und-V Det.	Low Voltage Detection
Nnd-V Det.	No Voltage Detection
Nnd-I Det.	No Current Detection
3U<<(27)	Three-Phase Undervoltage Protection
3U>(59)	Three-Phase Overvoltage Stage II Protection
3U>>(59)	Three-Phase Overvoltage Stage I Protection
FUSEF(60)	Fuse Fail Protection
Uub>	Unbalanced Voltage Protection

## Appendix A: 3AEH500 Protection Device Factory Default Settings Table

**Table I: 3AEH500 Protection Factory Default Setting Values**

<b>3AEH500 Protection Factory Default Setting</b>			
<b>Protection Name</b>	<b>Name</b>	<b>Description</b>	<b>Initialization Parameter</b>
Low Voltage Detection	DZU1	Low voltage setting	70V
	DZU2	Low voltage threshold	30V
Instantaneous Overcurrent	DZI1	Instantaneous overcurrent setting	10A
Definite-Time Overcurrent	DZI2	Definite-time overcurrent setting	7.5A
	DZT1	Definite-time overcurrent time setting	0.2S
Inverse-Time Overcurrent	DZI3	Inverse-time overcurrent setting	7A
	DZT2	Inverse-time overcurrent time setting	0.5S
Inverse-Time Overcurrent	DZI19	Inverse-time start current	6A
	IDMT1	Inverse-time curve constant	2
	K1	Inverse-time time constant	0.5
Zero-Sequence Overcurrent Alarm	DZI6	Zero-sequence alarm setting	7.5A
	DZT5	Zero-sequence alarm time setting	5S
Zero-Sequence Overcurrent Trip	DZI7	Zero-sequence trip setting	10A
	DZT6	Zero-sequence trip time setting	1S
Zero-Sequence Overcurrent Inverse-Time	DZI8	Zero-sequence inverse-time current	7A
	IDMT2	Zero-sequence inverse-time curve	2
	K2	Zero-sequence	0.5

		inverse-time	
Three-Phase Single-Shot Reclosing	DZT17	Group reset time	20S
	DZT16	Charging time setting	15S
	DZT11	Reclosing action time setting	0.5S
Accelerated Tripping After Closing	DZI4	Post-acceleration Current Setting	6.5A
	DZT13	Post-acceleration Effective Time	3S
	DZT30	Post-acceleration Time Setting	0.2S
Zero-sequence Overvoltage Alarm	DZU4	Zero-sequence Overvoltage Setting	120V
	DZT10	Zero-sequence Overvoltage Time Limit	5S
Control Circuit Abnormality	DZT24	Control Circuit Time Limit	10S
PT Disconnection Alarm	DZU5	Negative-sequence Overvoltage Setting	8V
	DZI9	Single-phase No-current Setting	0.3A
	DZU10	No-voltage/Loss of Voltage Setting	20V
	DZT25	PT Disconnection Time Limit	10S

**Table II: GLP Protection Device Unit Parameters Factory Default Values**

Parameter Item	Parameter Name	Parameter Default Value
CT/VT Settings	CT Ratio	100
	VT Ratio	100
	Measuring CT Secondary Rated Value	5A
	I01CT Secondary Rated Value	5A
Communication Settings	Communication Address	1
	Communication Rate	19200
	Communication Protocol IEC	IEC103
	Voltage Wiring Method	1 (Star Connection)

	Protection Two-phase/Three-phase Selection	Three-phase
Operation Settings	Setting Group	First Setting Group
	Language	Chinese
	Minimum Pulse Width for Opening and Closing	0.1 s
	User Password	0 0 0 0 0 0
Input Filtering Time	Input 1~10ms Filtering Time	20

## Appendix B: MODBUS-RTU Setting Function Codes and Address Table

### 1. Function Codes "01H", "05H": Read/Write or Multiple Switch Outputs

Address	Definition	Attribute	Object Type	Description
0000~0015	Reserved	R0	bit	
0016	Remote Control Opening	RW	bit	
0017	Remote Control Closing	RW	bit	
0018~0031	Reserved	WO	bit	
0032~0047	Reserved	RO	bit	
0048	KG1	RW	bit	Instantaneous Overcurrent Protection Enable/Disable
0049	KG2	RW	bit	Definite-time Overcurrent Protection Enable/Disable
0050	KG3	RW	bit	Inverse Time Overcurrent Protection Enable/Disable

0051	KG4	RW	bit	Post-closing Acceleration Enable/Disable
0052	KG5	RW	bit	Overload Warning Enable/Disable
0053	KG6	RW	bit	Overload Trip Enable/Disable
0054	KG7	RW	bit	Inverse Time Overcurrent Trip Enable/Disable
0055	KG8	RW	bit	Negative-sequence Overcurrent Section Enable/Disable
0056	KG9	RW	bit	Negative-sequence Overcurrent Section Enable/Disable
0057	KG10	RW	bit	Negative-sequence Inverse Time Overcurrent Enable/Disable
0058	KG11	RW	bit	Zero-sequence Alarm Enable/Disable
0059	KG12	RW	bit	Zero-sequence Trip Enable/Disable
0060	KG13	RW	bit	Zero-sequence Inverse Time Overcurrent Enable/Disable
0061	KG17	RW	bit	3I0 Overcurrent Enable/Disable
0062	KG20	RW	bit	Overvoltage Warning Enable/Disable
0063	KG21	RW	bit	Overvoltage Trip Enable/Disable
0064	KG22	RW	bit	Undervoltage Protection Enable/Disable
0065	KG23	RW	bit	Loss of Voltage Protection Enable/Disable
0066	KG24	RW	bit	Zero-sequence Overvoltage Enable/Disable

0067	KG25	RW	bit	Unbalanced Voltage Enable/Disable
0068	KG26	RW	bit	Definite-time Undervoltage Lockout
0069	KG27	RW	bit	Inverse Time Undervoltage Lockout
0070	KG28	RW	bit	Unbalanced Current Enable/Disable
0071	KG29	RW	bit	Unbalanced Voltage II Enable/Disable
0072	KG30	RW	bit	Start-up Time Too Long Enable/Disable
0073	KG31	RW	bit	Stall Protection Enable/Disable
0074	KG32	RW	bit	Loss of Voltage Auto-restart Enable/Disable
0075	KG33	RW	bit	Overheating Warning Enable/Disable
0076	KG34	RW	bit	Overheating Trip Enable/Disable
0077	KG38	RW	bit	Protection Start Reclosing
0078	KG41	RW	bit	No-current Lockout Enable/Disable
0079	KG42	RW	bit	No-voltage Lockout Enable/Disable
0080	KG43	RW	bit	PT Disconnection Alarm Enable/Disable
0081	KG44	RW	bit	Control Circuit Abnormality Enable/Disable
0082	KG45	RW	bit	Non-electrical 1 Quantity Alarm
0083	KG46	RW	bit	Non-electrical 1 Quantity Trip
0084	KG47	RW	bit	Non-electrical 2 Quantity Alarm
0085	KG48	RW	bit	Non-electrical 2 Quantity Trip
0086	KG49	RW	bit	PT Disconnection Lockout

0087	KG50	RW	bit	Incoming Line Through-line Enable/Disable
0088	KG51	RW	bit	Non-corresponding Reclosing
0089~0106	KG52~ KG79	RW	bit	User Control Words

## 2. Function Code "02H": Read Single or Multiple Digital Input States

Address	Definition	Attribute	Object Type	Description
0000~0013	Reserved	RO	bit	
0014	Reset or Parameter Modified Flag	RO	bit	
0015	SOE Existence Flag	RO	bit	
0016~0025	DI01~DI10	RO	bit	SOE
0026~0047	Reserved	RO	bit	SOE
0048	Instantaneous Overcurrent Protection Action	RO	bit	SOE
0049	Limited-time Overcurrent Protection Action	RO	bit	SOE
0050	Definite-time Overcurrent Protection Action	RO	bit	SOE
0051	Inverse Time Overcurrent Protection Action	RO	bit	SOE
0052	Zero-sequence Overcurrent Alarm	RO	bit	SOE
0053	Zero-sequence Overcurrent Trip	RO	bit	SOE
0054	Zero-sequence Overcurrent Inverse Time Action	RO	bit	SOE
0055	Three-phase Single Reclosing Action	RO	bit	SOE
0056	Post-closing Acceleration Action	RO	bit	SOE
0057	Zero-sequence Overvoltage Alarm	RO	bit	SOE
0058	Control Circuit Abnormality	RO	bit	SOE

0059	PT Disconnection Alarm	RO	bit	SOE
0060	Non-electrical 1 Quantity Alarm	RO	bit	SOE
0061	Non-electrical 1 Quantity Trip	RO	bit	SOE
0062	Non-electrical 2 Quantity Alarm	RO	bit	SOE
0063	Non-electrical 2 Quantity Trip	RO	bit	SOE
0064~0111	Reserved	RO	bit	SOE
0112	Remote Position	RO	bit	Panel has remote/local buttons to have this signal
0113	Local Position	RO	bit	

### 3. Function Codes "03H", "06H", "10H": Read/Write Registers

#### 3.1 Time

Address	Definition	Attribute	Object Type	Description
0000	Year, Month	RW	Unsigned Number	System Time
0001	Day, Hour	RW	Unsigned Number	System Time
0002	Minute, Second	RW	Unsigned Number	System Time
0003	Millisecond	RW	Unsigned Number	System Time

#### 3.2 Electrical degree

Address	Definition	Attribute	Object Type	Coefficient	Unit	Describe
0004	Forward Active Energy	RO	Unsigned Number	0.01	kWh	Low 16bit
0005	Forward Active Energy	RO				High 16bit
0006	Reverse Active Energy	RO	Unsigned Number	0.01	kVar h	Low 16bit

0007	Reverse Active Energy	RO				High 16bit
0008	Forward Reactive Energy	RO	Unsigned Number	0.01	kWh	Low 16bit
0009	Forward Reactive Energy	RO				High 16bit
0010	Reverse Reactive Energy	RO	Unsigned Number	0.01	kVar h	Low 16bit
0011	Reverse Reactive Energy	RO				High 16bit

Note: Electricity degree = High 16 bits × 65536 + Low 16 bits

### 3.3 Substation (R: 03H, W:06H)

Address	Definition	Attribute	Object Type
0149	Substation Setting	WO	Unsigned Number
0150	Substation Status	RO	Unsigned Number

#### 3.3.1 Substation status register (0150)

Bit Address	Definition	Description
Bit0~13	Reserved	
Bit14	Reset or Parameter Modified Flag	Used to refresh setting parameters
Bit15	SOE Existence Flag	Used to determine whether to read SOE

### 3.4 analog quantity

Addresses	Definition	Attribute	Object Type	Coefficient	Unit	Description
-----------	------------	-----------	-------------	-------------	------	-------------

0151	Ia	RO	Unsigned Number	0.01	A	Protection, Secondary Value
0152	Ib	RO	Unsigned Number	0.01	A	Protection, Secondary Value
0153	Ic	RO	Unsigned Number	0.01	A	Protection, Secondary Value
0154	I0	RO	Unsigned Number	0.01	A	Collected Zero-Sequence Current
0155	3I0	RO	Unsigned Number	0.01	A	Calculated Zero-Sequence Current
0156	I05	RO	Unsigned Number	0.01	A	5th Harmonic of I0
0157	I1	RO	Unsigned Number	0.01	A	Positive-Sequence Current
0158	I2	RO	Unsigned Number	0.01	A	Negative-Sequence Current
0159	IA	RO	Unsigned Number	0.1	A	Measurement, Primary Value
0160	IB	RO	Unsigned Number	0.1	A	Measurement, Primary Value
0161	IC	RO	Unsigned Number	0.1	A	Measurement, Primary Value
0162	Ua	RO	Unsigned Number	0.1	kV	Primary Value
0163	Ub	RO	Unsigned Number	0.1	kV	Primary Value
0164	Uc	RO	Unsigned Number	0.1	kV	Primary Value
0165	Uab	RO	Unsigned Number	0.1	kV	Primary Value
0166	Ubc	RO	Unsigned Number	0.1	kV	Primary Value
0167	Uca	RO	Unsigned Number	0.1	kV	Primary Value
0168	3U0	RO	Unsigned Number	0.1	kV	Calculated Zero-Sequence Voltage

0169	Un	RO	Unsigned Number	0.1	kV	Collected Zero-Sequence Voltage
0170	P	RO	Unsigned Number	0.1	kW	Active Power
0171	Q	RO	Unsigned Number	0.1	kVar	Reactive Power
0172	PF	RO	Unsigned Number	0.001		Power Factor
0173	f	RO	Unsigned Number	0.01	Hz	Frequency

### 3.5 Settings

Address	Definition	Attribute	Range	Coefficient	Unit	Description
0400	DZI1	RW	0~99.00	0.01	A	Instantaneous Overcurrent Setting
0401	DZI2	RW	0~99.00	0.01	A	Definite-Time Overcurrent Setting
0402	DZI3	RW	0~99.00	0.01	A	Inverse-Time Overcurrent Setting
0403	DZI4	RW	0~99.00	0.01	A	Post-Acceleration Current Setting
0404	DZI5	RW	0~99.00	0.01	A	Overload Alarm Current
0405	DZI6	RW	0~99.00	0.01	A	Zero-Sequence Alarm Setting
0406	DZI7	RW	0~99.00	0.01	A	Zero-Sequence Trip Setting
0407	DZI8	RW	0~99.00	0.01	A	Zero-Sequence Inverse-Time Current
0408	DZI9	RW	0~99.00	0.01	A	Single-Phase No-Current Setting
0409	DZI10	RW	0~99.00	0.01	A	Negative-Sequence Stage 1 Setting
0410	DZI11	RW	0~99.00	0.01	A	Negative-Sequence Stage 2 Setting
0411	DZI12	RW	0~99.00	0.01	A	Start-Up Time Too Long Current
0412	DZI13	RW	0~99.00	0.01	A	Motor Starting Current
0413	DZI14	RW	0~99.00	0.01	A	Stalling Current Setting

0414	DZI15	RW	0~99.00	0.01	A	High Instantaneous Overcurrent Setting
0415	DZI16	RW	0~99.00	0.01	A	3I0 Overcurrent Setting
0416	DZI17	RW	0~99.00	0.01	A	Unbalanced Current Setting
0417	DZI18	RW	0~99.00	0.01	A	Motor Rated Current
0418	DZI19	RW	0~99.00	0.01	A	Inverse-Time Start-Up Current
0419	DZI20	RW	0~99.00	0.01	A	Negative-Sequence Inverse-Time Start-Up
0420~0429	DZI21	RW	0~99.00	0.01	A	Reserved Current Settings
0430	DZU1	RW	0~120.0 0	0.01	V	Undervoltage Setting
0431	DZU2	RW	0~120.0 0	0.01	V	Undervoltage Threshold
0432	DZU3	RW	0~120.0 0	0.01	V	Busbar Loss of Voltage Setting
0433	DZU4	RW	0~120.0 0	0.01	V	Zero-Sequence Overvoltage Setting
0434	DZU5	RW	0~120.0 0	0.01	V	Negative-Sequence Overvoltage Setting
0435	DZU6	RW	0~120.0 0	0.01	V	PT Calculated Zero-Sequence Value
0436	DZU7	RW	0~120.0 0	0.01	V	Overvoltage Alarm Setting
0437	DZU8	RW	0~120.0 0	0.01	V	Overvoltage Trip Setting
0438	DZU9	RW	0~120.0 0	0.01	V	PT Disconnection Voltage Value
0439	DZU10	RW	0~120.0 0	0.01	V	No-Voltage/Loss of Voltage Setting
0440	DZU11	RW	0~120.0 0	0.01	V	Voltage Presence Setting
0441	DZU12	RW	0~120.0 0	0.01	V	Unbalanced Voltage Setting
0442	DZU13	RW	0~120.0 0	0.01	V	Opposite Side Voltage Presence Setting

0443	DZU14	RW	0~120.0 0	0.01	V	Composite Voltage Negative-Sequence Value
0444	K1	RW	0~1	0.01		Inverse-Time Time Constant
0445	K2	RW	0~1	0.01		Zero-Sequence Inverse-Time Time
0446	K3	RW	0~1	0.01		Negative-Sequence Inverse-Time Time
0447	IDMT1	RW	0~3	1		Inverse-Time Curve Constant
0448	IDMT2	RW	0~3	1		Inverse-Time Curve Constant
0449	IDMT3	RW	0~3	1		Inverse-Time Curve Constant
0450	N1	RW	0~10	1		Heat Dissipation Time Multiplier
0451	N2	RW	0~10	1		Negative-Sequence Current Heating Constant
0452	DZT1	RW	0~99.00	0.005	S	Definite-Time Overcurrent Time Setting
0453	DZT2	RW	0~99.00	0.005	S	Inverse-Time Time Setting
0454	DZT3	RW	0~99.00	0.005	S	Overload Alarm Time
0455	DZT4	RW	0~99.00	0.005	S	Overload Trip Time
0456	DZT5	RW	0~99.00	0.005	S	Zero-Sequence Alarm Time Limit
0457	DZT6	RW	0~99.00	0.005	S	Zero-Sequence Trip Time Limit
0458	DZT6	RW	0~99.00	0.005	S	Through-Line Time Limit
0459	DZT8	RW	0~99.00	0.005	S	Through-Line Effective Time
0460	DZT9	RW	0~99.00	0.005	S	
0461	DZT10	RW	0~99.00	0.005	S	Zero-Sequence Overvoltage Time Limit
0462	DZT11	RW	0~99.00	0.005	S	Reclosing Action Time Limit
0463	DZT12	RW	0~99.00	0.005	S	Reclosing Effective Time

0464	DZT13	RW	0~99.00	0.005	S	Post-Acceleration Effective Time
0465	DZT14	RW	0~99.00	0.005	S	Negative-Sequence Stage Time Limit
0466	DZT15	RW	0~99.00	0.005	S	Negative-Sequence Stage Time Limit
0467	DZT16	RW	0~99.00	0.005	S	Charging Time Setting
0468	DZT17	RW	0~99.00	0.005	S	Entire Group Reset Time
0469	DZT18	RW	0~99.00	0.005	S	Overvoltage Alarm Time Limit
0470	DZT19	RW	0~99.00	0.005	S	Overvoltage Trip Time Limit
0471	DZT20	RW	0~99.00	0.005	S	Undervoltage Time Setting
0472	DZT21	RW	0~99.00	0.005	S	Loss of Voltage Time Setting
0473	DZT22	RW	0~99.00	0.005	S	Unbalanced Current Time Limit
0474	DZT23	RW	0~99.00	0.005	S	Unbalanced Voltage Time Limit
0475	DZT24	RW	0~99.00	0.005	S	Control Circuit Time Limit
0476	DZT25	RW	0~99.00	0.005	S	PT Disconnection Time Limit
0477	DZT26	RW	0~99.00	0.005	S	Motor Starting Time
0478	DZT27	RW	0~99.00	0.005	S	Stalling Time Setting
0479	DZT28	RW	0~99.00	0.005	S	Loss of Voltage Restart Time Limit
0480	DZT29	RW	0~99.00	0.005	S	I Overcurrent Time Limit
0481	DZT30	RW	0~99.00	0.005	S	Post-Acceleration Time Setting
0482	DZT31	RW	0~99.00	0.005	S	Undervoltage Detection Time Limit
0483	DZT32	RW	0~99.00	0.005	S	Unbalanced Voltage Stage 2
0484~0489	DZT33~DZT38	RW	0~99.00	0.005	S	Reserved Time Settings
0490	DZT39	RW	0~99.00	0.005	M	Overheating Alarm Time Constant

0491	DZT40	RW	0~99.00	0.005	M	Overheating Trip Time Constant
0492~0499	DZT41~DZT48	RW	0~99.00	0.005	M	Reserved Long Delay Settings

## Appendix C: IEC60870-5-103 Protocol Setting Value Function Codes and Address Table

**Table 1: Telemetry (ASDU50)**

Function Type: 01H

Starting Information Sequence: 5CH

Sequence	Name	Definition	Unit	Description
1	Measured Value MEA1	Ia	A	Protection, Secondary Value
2	Measured Value MEA2	Ib	A	Protection, Secondary Value
3	Measured Value MEA3	Ic	A	Protection, Secondary Value
4	Measured Value MEA4	I0	A	Protection, Secondary Value
5	Measured Value MEA5	3I0	A	Protection, Secondary Value
6	Measured Value MEA6	I05	A	Protection, Secondary Value
7	Measured Value MEA7	I1	A	Protection, Secondary Value
8	Measured Value MEA8	I2	A	Protection, Secondary Value
9	Measured Value MEA9	IA	A	Measurement, Secondary Value
10	Measured Value MEA10	IB	A	Measurement, Secondary Value
11	Measured Value MEA11	IC	A	Measurement, Secondary Value
12	Measured Value MEA12	Ua	V	Secondary Value
13	Measured Value MEA13	Ub	V	Secondary Value
14	Measured Value MEA14	Uc	V	Secondary Value

15	Measured Value MEA15	Uab	V	Secondary Value
16	Measured Value MEA16	Ubc	V	Secondary Value
17	Measured Value MEA17	Uca	V	Secondary Value
18	Measured Value MEA18	3U0	V	Secondary Value
19	Measured Value MEA19	Un	V	Secondary Value
20	Measured Value MEA20	P	W	Secondary Value
21	Measured Value MEA21	Q	Var	Secondary Value
22	Measured Value MEA22	PF		Power Factor
23	Measured Value MEA23	f	Hz	Frequency

**Table 2: Telesignalling (ASDU1)**

Function Type	Information Sequence	Definition	Description
1	1	DI1	Digital Input
1	2	DI2	Digital Input
1	3	DI3	Digital Input
1	4	DI4	Digital Input
1	5	DI5	Digital Input
1	6	DI6	Digital Input
1	7	DI7	Digital Input
1	8	DI8	Digital Input
1	9	DI9	Digital Input
1	10	DI10	Digital Input
1	11~32	Reserved	Reserved
1	33	SOE (32)	Instantaneous Overcurrent Protection Action
1	34	SOE (33)	Definite-time Overcurrent Protection Action
1	35	SOE (34)	Inverse-time Overcurrent Protection Action
1	36	SOE (35)	Zero-sequence Overcurrent Warning
1	37	SOE (36)	Zero-sequence Overcurrent Trip
1	38	SOE (37)	Zero-sequence Overcurrent Inverse-time Action

1	39	SOE (38)	Three-phase Once Reclosing Action
1	40	SOE (39)	Post-accelerated Protection Action
1	41	SOE (40)	Zero-sequence Overvoltage Warning
1	42	SOE (41)	Control Circuit Abnormality
1	43	SOE (42)	PT Disconnection Warning
1	44	SOE (43)	Non-electric Quantity 1 Warning
1	45	SOE (44)	Non-electric Quantity 1 Trip
1	46	SOE (45)	Non-electric Quantity 2 Warning
1	47	SOE (46)	Non-electric Quantity 2 Trip
1	48	SOE (47)	Reserved
1	49~112	Reserved	Reserved
133	113	KG1	Instantaneous Overcurrent Enable/Disable
133	114	KG2	Definite-time Overcurrent Enable/Disable
133	115	KG3	Inverse-time Overcurrent Enable/Disable
133	116	KG4	Post-accelerated Overcurrent Enable/Disable
133	117	KG5	Overload Warning Enable/Disable
133	118	KG6	Overload Trip Enable/Disable
133	119	KG7	Inverse-time Protection Enable/Disable
133	120	KG8	Negative-sequence Segment 1 Enable/Disable
133	121	KG9	Negative-sequence Segment 2 Enable/Disable
133	122	KG10	Negative-sequence Inverse-time Enable/Disable
133	123	KG11	Zero-sequence Warning Enable/Disable
133	124	KG12	Zero-sequence Trip Enable/Disable
133	125	KG13	Zero-sequence Inverse-time Enable/Disable
133	126	KG17	3I0 Overcurrent Enable/Disable
133	127	KG20	Overvoltage Warning Enable/Disable
133	128	KG21	Overvoltage Trip Enable/Disable
133	129	KG22	Undervoltage Protection Enable/Disable
133	130	KG23	Loss of Voltage Protection

			Enable/Disable
133	131	KG24	Zero-sequence Overvoltage Warning Enable/Disable
133	132	KG25	Unbalanced Voltage Enable/Disable
133	133	KG26	Definite-time Undervoltage Blocking
133	134	KG27	Inverse-time Undervoltage Blocking
133	135	KG28	Unbalanced Current Enable/Disable
133	136	KG29	Unbalanced Voltage 2 Enable/Disable
133	137	KG30	Start-up Timeout Enable/Disable
133	138	KG31	Stall Protection Enable/Disable
133	139	KG32	Auto-restart Under Voltage Enable/Disable
133	140	KG33	Overheating Warning Enable/Disable
133	141	KG34	Overheating Trip Enable/Disable
133	142	KG38	Protection Start Reclosing
133	143	KG41	No-current Blocking Enable/Disable
133	144	KG42	No-voltage Blocking Enable/Disable
133	145	KG43	PT Disconnection Enable/Disable
133	146	KG44	Control Circuit Abnormality
133	147	KG45	Non-electric Quantity 1 Warning
133	148	KG46	Non-electric Quantity 1 Trip
133	149	KG47	Non-electric Quantity 2 Warning
133	150	KG48	Non-electric Quantity 2 Trip
133	151	KG49	PT Disconnection Blocking
133	152	KG50	Incoming Line Connection Enable/Disable
133	153	KG51	Non-corresponding Reclosing
133	154~181	KG52~KG79	User Control Words
133	182~192	Reserved	Reserved
1	193~245	Reserved	Reserved
1	246	SOE	Remote Protection Reset
1	247	SOE	Local Protection Reset
1	278	SOE	Self-test Error
1	249	SOE	Self-test Correct
1	250	SOE	Device Power-down

1	251	SOE	Device Power-up
1	252	SOE	Device Reset
1	253	SOE	Local Operation Output
1	254	SOE	Remote Control Operation
1	255	SOE	Protection Setting Modified

**Table 3: Electricity Metering (ASDU36)**

Function Type: 01H

Starting Information Sequence: 06H

Sequential notation	Name	Coefficient	Unit
1	Forward Active Energy	0.01	kWh
2	Reverse Active Energy	0.01	kVarh
3	Forward Reactive Energy	0.01	kWh
4	Reverse Reactive Energy	0.01	kVarh

**Table 4: Remote Control (ASDU64)**

Function Type	Information Sequence	Definition	Description
1	01	OUT1	Open
1	02	OUT2	Close
1	81	KG1	Instantaneous Overcurrent Enable/Disable
1	82	KG2	Definite-time Overcurrent Enable/Disable
1	83	KG3	Inverse-time Overcurrent Enable/Disable
1	84	KG4	Post-accelerated Overcurrent Enable/Disable
1	85	KG5	Overload Warning Enable/Disable
1	86	KG6	Overload Trip Enable/Disable
1	87	KG7	Inverse-time Protection Enable/Disable
1	88	KG8	Negative-sequence Segment 1 Enable/Disable
1	89	KG9	Negative-sequence Segment 2 Enable/Disable
1	90	KG10	Negative-sequence

			Inverse-time Enable/Disable
1	91	KG11	Zero-sequence Warning Enable/Disable
1	92	KG12	Zero-sequence Trip Enable/Disable
1	93	KG13	Zero-sequence Inverse-time Enable/Disable
1	94	KG17	3I0 Overcurrent Enable/Disable
1	95	KG20	Overvoltage Warning Enable/Disable
1	96	KG21	Overvoltage Trip Enable/Disable
1	97	KG22	Undervoltage Protection Enable/Disable
1	98	KG23	Loss of Voltage Protection Enable/Disable
1	99	KG24	Zero-sequence Overvoltage Warning Enable/Disable
1	100	KG25	Unbalanced Voltage Enable/Disable
1	101	KG26	Definite-time Undervoltage Blocking
1	102	KG27	Inverse-time Undervoltage Blocking
1	103	KG28	Unbalanced Current Enable/Disable
1	104	KG29	Unbalanced Voltage 2 Enable/Disable
1	105	KG30	Start-up Timeout Enable/Disable
1	106	KG31	Stall Protection Enable/Disable
1	107	KG32	Auto-restart Under Voltage Enable/Disable
1	108	KG33	Overheating Warning Enable/Disable
1	109	KG34	Overheating Trip Enable/Disable
1	110	KG38	Protection Start Reclosing
1	111	KG41	No-current Blocking Enable/Disable
1	112	KG42	No-voltage Blocking Enable/Disable
1	113	KG43	PT Disconnection Enable/Disable
1	114	KG44	Control Circuit Abnormality
1	115	KG45	Non-electric Quantity 1 Warning
1	116	KG46	Non-electric Quantity 1 Trip
1	117	KG47	Non-electric Quantity 2 Warning
1	118	KG48	Non-electric Quantity 2 Trip

---

1	119	KG49	PT Disconnection Blocking
1	119	KG50	Incoming Line Connection Enable/Disable
1	120	KG51	Non-corresponding Reclosing